

The Ameco Converter, Model CN, is a crystal-controlled broadband converter with a very low noise figure, very high gain and excellent image and spurious rejection. When used in conjunction with a receiver, it will provide reception of the desired VHF amateur band. The CN-50 covers 50-54 Mc., the CN-144 covers 144 to 148 Mc. and the CN-220 covers 220 to 225 Mc. The converter uses a type 6CW4 or 6DS4 Nuvistor tube as the first RF amplifier, a 6CW4 or 6DS4 Nuvistor as the second RF amplifier and a 6CW4 or 6DS4 as the mixer. A 6J6 serves as the crystal controlled oscillator and multiplier.

The circuitry used, together with considerable internal shielding and bypassing, provide high sensitivity to the desired signals and maximum rejection of spurious, undesired signals. A novel feature of this unit is the fact that the output frequency may be changed quite simply. This feature prevents the converter from becoming obsolete when the receiver is changed to a different type. The MARS and CAP frequencies near the 2-meter band are also covered with the CN-144 converter.

POWER REQUIREMENTS

The converter uses 6.3V. at 0.855 Amps for the filaments and 100 to 125 V. DC at 25 Ma. for the plates. This power may be obtained most conveniently from the companion Ameco Power Supply, Model PS-1, which plugs together with the converter directly. No cable is needed. Many receivers have accessory sockets and sufficient power to operate the converter. Do not attempt to take power from an AC-DC receiver. In the event that power for the converter is taken from the receiver or some other source, wire the socket that will mate with the converter plug so that the receiver chassis is connected to pin 2, the hot side of the 6.3 volt filament to pin 7, and B+ (100 to 125V.) to pin 8. (See the schematic).

If the power supply delivers over 125 volts, add a resistor in series with the B+ lead (Pin 8) and a voltage regulator tube type OB2 or OC3/VR105 across B+ (pin 8) to chassis. The voltage regulator is needed to maintain the operating voltages constant when the manual gain control on the CN converter is adjusted. See Fig. 1. NOTE: If the voltage is over 125 volts at the converter pin 8, the crystal and one or more tubes can be destroyed.

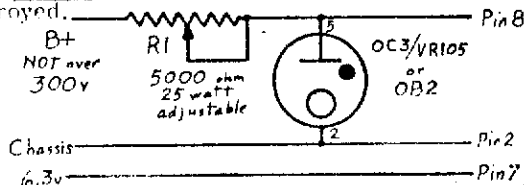

22-26M

Fig. 1. Adjust R1 for 45 ma. through it, at normal line voltage.

12 VOLT OPERATION

If it is desired to use 12 volts instead of 6 volts for the filaments of the converter, the filaments can be rewired as follows: (See schematic)

1. Remove the brown wire that connects pin 7 of the power plug to the feedthru condensers.
2. Cut the wire that connects pin 3 of the 6J6 to ground.
3. Cut a small notch in the rear part of the shield closest to the power plug, near the feedthru condensers, above X4, to pass one wire.
4. Using short lead lengths, connect a .001 disc ceramic condenser from pin 3 of the 6J6 socket to the chassis.
5. Connect a new wire from pin 3 of the 6J6 socket to pin 7 of the power plug. Tape this wire at the point where it passes through the notch in the shield so as to prevent it from being cut by the shield.
6. Connect two 270 ohm, 1/2 watt resistors in parallel. Connect one end of this pair of resistors to the feedthru condenser from where the brown wire was removed in step 1 above. Ground the other end of this resistor to the shield.

CABLES and CONNECTORS

The connections to the input and output of the converter should be made with 50 ohm coaxial cable (RG8/U or RG58/U) terminated with auto radio-antenna plugs (Ameco #AP-1 or Cinch #1320). The cable is connected to the plug in the manner shown in Fig. 2.

- Remove outer vinyl covering for 1-7/8".
- Strip braid and inner insulation off center conductor for 7/8".
- Push braid back to form a bead all around.
- Insert center conductor through plug pin until braid is against end of plug.
- Bend center conductor to hold plug in place.
- Roll braid between fingers to roll it over the end of the plug for about 1/16".
- Solder the braid to the four tabs of the plug.
- Solder the center conductor to the pin and cut off excess wire.

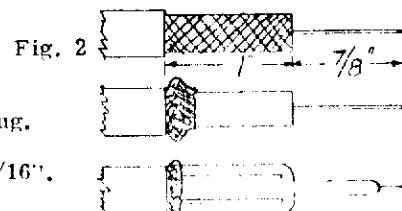

The coaxial cable from the output of the converter to the receiver can be up to a maximum of about three feet. If some undesired IF signals are getting through, the chances are that it is due to the long ground wire (at the antenna terminal strip) inside most receivers. A short jumper wire (not over 1/2 inch) between the converter chassis and the receiver chassis will usually correct this.

A number of amateurs have requested that we supply converters with SO-239 or BNC connectors instead of the auto radio plugs. The auto radio plugs we use are in the "absolutely reliable" class; no contact trouble occurs unless there is considerable physical damage to the plug or jack contact surfaces. The cable fasten-

are simple to make. They are easy to connect and disconnect as no locking ring or threaded sleeve must be handled. They are not expensive like the BNC. They do not come loose like a PL259. The losses in the VHF range are not measurably different when any of the three types are compared. The only reason for using BNC connectors is where all other connections in the station are made with BNC's. In this case, either an adapter BNC to auto radio connector can be made easily or the jacks removed from the converter and the one-hole-mount BNC jack substituted. The hole is the correct size.

ANTENNA REQUIREMENTS

Any type of antenna, except long wire, may be used with this converter. A rotatable beam is preferred; however, a quarter wave whip, a ground plane, a beam or halo type may be used. While the input and output impedance is not critical, it is nominally 50 ohms and 50 ohm coaxial cable should be used between the antenna and the converter. 75 ohms will work well also. If the antenna terminates at 300 ohms and 300 ohm transmission line is used, then a matching balun should be used between the line and the converter.

SELECTING THE OUTPUT IF FREQUENCY

This converter may be adjusted so that it will provide any output frequency between 0.5 Mc. and 35 Mc. for the CN-50, and 0.5 Mc. and 55 Mc. on the CN-144 and CN-220. This feature of the converter will prevent it from becoming obsolete should the receiver be changed to a different type.

If there is a choice as to what output frequency to use, it is recommended that a low output frequency be used - preferably 7-11 Mc. This is because most receivers perform best in this range. Their oscillator stability (drift), image and spurious rejection become progressively poorer as the frequency goes up.

On receivers covering ham bands only, the 28-30 Mc. band gives the most coverage for use with a converter.

The following table shows the crystal frequencies to be used to obtain the various IF outputs from the converter and any other changes required. See drawing of L6 (A7596C) terminal arrangement on Page 5 for position of the jumper.

FREQUENCY TABLES

CN-50					
To Receive Mc.	IF Output Mc.	Crystal Mc.	C23 mmfd. See Note B	L6 Jumper	L7 Link
50-54	7-11	43	Not used	Remove jumper	Next to winding
50-54	10-14	40	Not used	from B to A	Over winding
50-54	14-18	36	5	from B to F	Over winding
50-54	26-30	24	22	from B to E	Over winding
50-54	28-32	22	22	from B to E	Over winding
50-54	30.5-34.5 Note E	19.5	50	from B to E	Over winding
50-51)	Broadcast	49.4	Not used	See Note A	Next to winding
51-52)	(600-1600 Kc.)	50.4	Not used	See Note A	Next to winding

CN-144							
To Receive Mc.	IF Output Mc.	Crystal Mc.	Multiplier Output Mc.	C31 mmfd. See Note B	L8 Turns	L7 Link	L6 Jumper
144-148	7-11	45.6667	137	Not used	7	Next to winding	Remove jumper
144-148	10-14	44.6667	134	Not used	7	Next to winding	From B to A
144-148	14-18	43.3333	130	Not used	7	Next to winding	From B to F
144-148	26-30	39.3333	118	5	7	Over winding	From B to E
144-148	28-32 Note C	38.6667	116	5	7	Over winding	From B to E
144-148	30.5-34.5 Note E	37.8333	113.5	5	8	Over winding	From B to E
144-148	50-54	31.3333	94	10	9	Over winding	See Note D
144-145)	Broadcast	47.8000	143.4	Not used	7	Next to winding	See Note A
145-146)	(600-1600 Kc.)	48.1333	144.4	Not used	7	Next to winding	See Note A
146-147)		48.4667	145.4	Not used	7	Next to winding	See Note A

CN-220						
To Receive Mc.	IF Output Mc.	Crystal Mc.	Multiplier Output Mc.	C31 mmfd. See Note B	L7 Link	L6 Jumper
220-225	7 to 12	53.2500	213	Not used	Next to winding	Remove jumper
220-225	10 to 15	52.5000	210	Not used	Next to winding	From B to A
220-225	14 to 19	51.5000	206	Not used	Next to winding	From B to F
220-225	26 to 31	48.5000	194	Not used	Next to winding	From B to E
20-225	28 to 33	48.0000	192	Not used	Next to winding	From B to E (see Note C)
20-225	30 to 35 Note E	47.5000	190	Not used	Next to winding	From B to E
20-225	50 to 55	42.5000	170	5	Next to winding	See Note D
0-225	Broadcast	Not recommended				

TE A: L6 jumper can be in any position as it does not operate on broadcast. Remove the 330 ohm resistor and 100 mmfd. condenser from J2.

NOTE B: C23 or C31 is a capacitor that is connected from the crystal socket X5 pin #1 to L7 terminal nearest to the side of the chassis.

NOTE C: In many Amateur Band only receivers, the best band for use with converters is the 28 to 30 Mc. band. As an example: to cover 144 to 148 Mc., two crystals can be used: a 38.6667 Mc. crystal will permit reception of 144 to 146 Mc. and a 39.3333 Mc. crystal will permit reception of 146 to 148 Mc. The oscillator can be adjusted for good performance with both crystals without retuning when crystals are changed.

NOTE D: Add Ameco Coil #RL-3254 from B to C.

NOTE E: Cut R8 from terminal C on L6 and solder it to terminal B.

ALIGNMENT

All wired and tested converters have been carefully aligned and their performance measured with laboratory test equipment. Then they are checked on the air. If your antenna is close to 50 ohms, no adjustments are needed.

INSTRUMENTS REQUIRED:

1. Vacuum tube voltmeter or sensitive voltohmmeter.
2. Signal generator or other signal source such as a VFO, a heterodyne frequency meter or a transmitter.
3. Receiver.
4. Aligning tools, including a .100" hexagonal plastic or nylon alignment wrench.

ALIGNMENT PROCEDURE:

Alignment must be performed with the bottom cover in place. You will note two holes through which you can adjust the alignment trimmers, C13 (or C16) and C5.

CN ALIGNMENT - ALL MODELS

1. Adjust the six piston trimmers on top of the CN-144 or CN-220 chassis so that 1/2" of the trimmer screw is exposed above the trimmer housing. Adjust the six hexagonal core slugs on the CN-50 and the single hexagonal core slug on the CN-144 and CN-220 so that the slugs are approximately centered in the coils. Connect the converter to your receiver and power supply. Connect VTVM from the test point TP to ground. See Fig. 3 for the location of this point. Adjust the VTVM to a low scale setting to read -DC volts. Wherever 6CW4 is mentioned, 6CW4 or 6DS4 can be used without changes or adjustments.

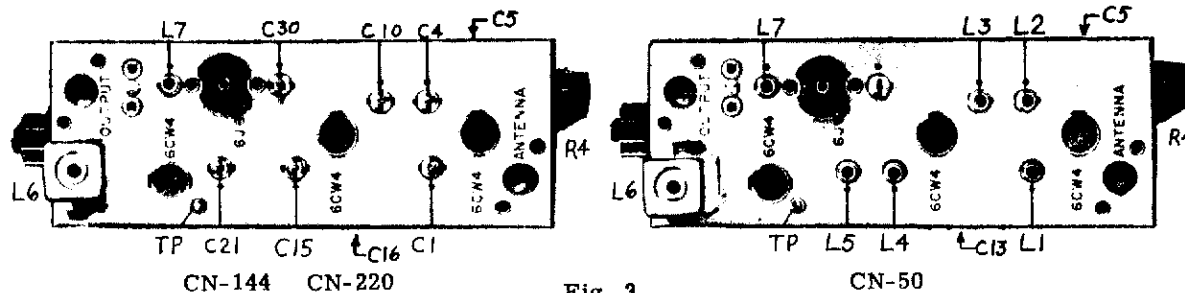

Fig. 3

2. Insert V4 - 6J6 oscillator-multiplier and V3 - 6CW4 mixer only. Oscillator alignment: Turn L7 counter-clockwise until the slug is at the top of the housing.
3. Turn L7 clockwise until the VTVM goes to a maximum reading and then drops sharply. At this point, turn L7 one turn counter-clockwise. If no reading is obtained at the test point, connect the VTVM through a 100K resistor to pin 5 of X4 to check the oscillator. Typical readings are -5 to -18 volts maximum, depending on crystal and crystal frequency. Should you fail to get a reading of over -4 volts at this point, it is an indication of a malfunction in the oscillator circuit. If the reading at this point is normal in the CN-50 and you get no reading at point TP, check the unit for wiring error or omission in the mixer or oscillator stage. If the reading at this point is normal in the CN-144 or CN-220 and you get no reading at point TP, it is an indication of a probable gross missetting of capacitor C-30 or an error in wiring in the mixer stage.
4. (Models CN-144 and CN-220 only). With the VTVM at test point TP, adjust C30 for maximum.

NOTE: DO NOT disconnect the VTVM from the test point TP until the alignment is completed.

5. There will be a drop in voltage on the VTVM if we remove the crystal. Adjust L7 until the difference in voltage between the crystal in and the crystal out is no less than 1.0 volt and no more than 1.7 volts. For instance, an optimum reading is -2.2 volts with the crystal in and -0.5 volt with the crystal out.
6. Insert V2 - 6CW4 - 2nd RF amplifier. Turn the gain control fully clockwise. Remove the crystal from the socket and set it aside.
7. Adjust the 2nd RF stage neutralizing capacitor (C-13 on the 50 Mc. models, C-16 on the 144 Mc. and 220 Mc. models) through the left side hole on the bottom-cover of the chassis. The left hole is the one furthest away from the front of the chassis. Do not confuse this with the hole in the right side of the bottom

cover which is closer to the front of the chassis. Adjust this 2nd stage neutralizing trimmer by turning it clockwise until the VTVM swings up scale (indicating oscillation). At this point, SLOWLY turn the trimmer counterclockwise one half turn past the point where the oscillation stops. This must be done with an insulated screwdriver (the type with a very small steel piece in the end of a plastic rod).

8. Insert V1 - 6CW4, 1st RF amplifier. Adjust C5 (the 1st RF stage neutralizing capacitor located through the side hole on the right side of the bottom cover, closest to the front of the chassis) using the same procedure as in step 7.

9. Feed in a signal to J1 at about 50.5, 146 or 221.5 Mc., depending on your model, and tune L2, 3, 4, 5 on the 50 Mc. unit (or C1, C4, C10, C15, C21 on the 144 or 220 Mc. units) for maximum. Keep the output below 3 volts by reducing the signal input as you proceed through the alignment steps. If voltage will not go down, repeat steps 7 and 8.

10. Disconnect R2 at point A, increase the signal strength enough to move the meter 1/4 to 1/2 volt and readjust C5 for MINIMUM meter reading.

11. Reconnect R2 to point A but do not solder.

12. Disconnect R5 from point B and repeat step 10, adjusting C13 or C16 instead.

13. Reconnect R5 to point B but DO NOT solder.

MODEL CN-50 ONLY

14a. Tune the signal source to 51 Mc. and adjust L4 and L5 for maximum output on the VTVM.

14b. Tune the signal source to 50 Mc. and adjust L2 and L3 for maximum output on the VTVM.

14c. Tune the signal source to 49.5 Mc. and adjust L1 bottom core for maximum output (this tunes broadly).

14d. Tune the signal source to 50.5 Mc. and adjust L1 top core for maximum output (this tunes broadly).

NOTES: If there is any pronounced peak when tuning across the band, L2 can be adjusted slightly to smooth the response. It seldom requires more than one turn.

Bandwidth is controlled by the position of the "figure 8" links on L2 and L5. Typical adjustment is with the link at the end of the winding on L2 but not covering any turns. The other end of the link should be around the winding of L3. The other link should be around the winding of L4 and near the end of L5, covering 2 or 3 turns. Bandwidth is increased by moving the links to cover more of the windings on L2 and L5, decreased by bending the links away from the windings. Mid-band gain is little affected by these adjustments.

MODEL CN-144 ONLY

14a. Tune the signal source to 148.0 Mc. and adjust C4 and C21 for maximum output on the VTVM.

14b. Tune the signal source to 150 Mc. and adjust C10 for maximum output. If 150Mc. is not available, tune at 148 Mc. and turn C10 two turns counter-clockwise from the peak reading.

14c. Tune the signal source to 144 Mc. and adjust C1 and C15 for maximum output. Then turn C1 - 2 turns CW.

NOTE: If there is any pronounced peak in noise when tuning across the band, C4 can be adjusted slightly to smooth the response on CN-144, C10 on CN-220. It seldom requires more than one turn.

MODEL CN-220 ONLY

To align the CN-220, the bottom cover must be removed.

A loading unit consisting of a .001 mfd. ceramic capacitor in series with a 1000 ohm carbon resistor will be required. The leads must be very short. To use the loading unit, connect it across the coil or from the hot side of the coil to the chassis. If it is fastened to a plastic rod, it will be most convenient to use.

14a. Tune the signal source to 220 Mc. and adjust C1 for maximum output, then detune one turn clockwise.

14b. Tune the signal source to 222.5 Mc. and adjust C4 for maximum output with load across L3.

14c. Tune the signal source to 222.5 Mc. and adjust C10 for maximum output with load across L2.

14d. Tune the signal source to 222.5 Mc. and adjust C15 for maximum output with load across L5.

14e. Do not adjust C21.

ALL MODELS

15. Step 14 for all models should be repeated at least once as there is interaction between the various adjustments.

16. Insert the crystal and tune the receiver to the center of the band of interest - 51 Mc., 146 Mc., 222.5 Mc.

17. In this step, do not attempt to use the "S" meter on your receiver. Turn off the AVC circuit or keep the signal level so low that the slightest change in noise level from the speaker will be quite noticeable. Carefully adjust L6 for maximum audio output. Typical settings are as follows: 7-11 Mc., the slug near the top of the can. 14-18 Mc., the slug near the center of the can. 28-30 Mc., the slug near the bottom of the can. There will be no changes in voltage at test point TP during this step.

18. To check for stability, reduce the signal input from the generator and rotate the gain control from full clockwise to full counterclockwise several times while watching the VTVM. The voltage at point TP should not vary very much. If the meter jumps up or down the scale, the neutralization adjustments must be repeated (steps 10, 11, 12 and 13).

19. Disconnect the signal generator and repeat the checks in step 18.

20. Connect the antenna and repeat the checks in step 18.

21. If it all checks OK, solder points A and B.

Note that if, at a later date, or with change of antenna, the RF amplifier oscillates, a quarter turn on C5, or occasionally C13 or C16 will stop the oscillation. It is not necessary to go through the original procedure. Normally no adjustment is required when tubes are replaced.

22. Repeat steps 4 and 5 to adjust the oscillator injection level.

NOTE: The above procedures will give satisfactory results with the commonly available test equipment usually found in an amateur station. If you have a good sweep generator, marker generator and oscilloscope, somewhat more even gain can be produced, usually within ± 1.5 db.

SCHEMATICS

CN50

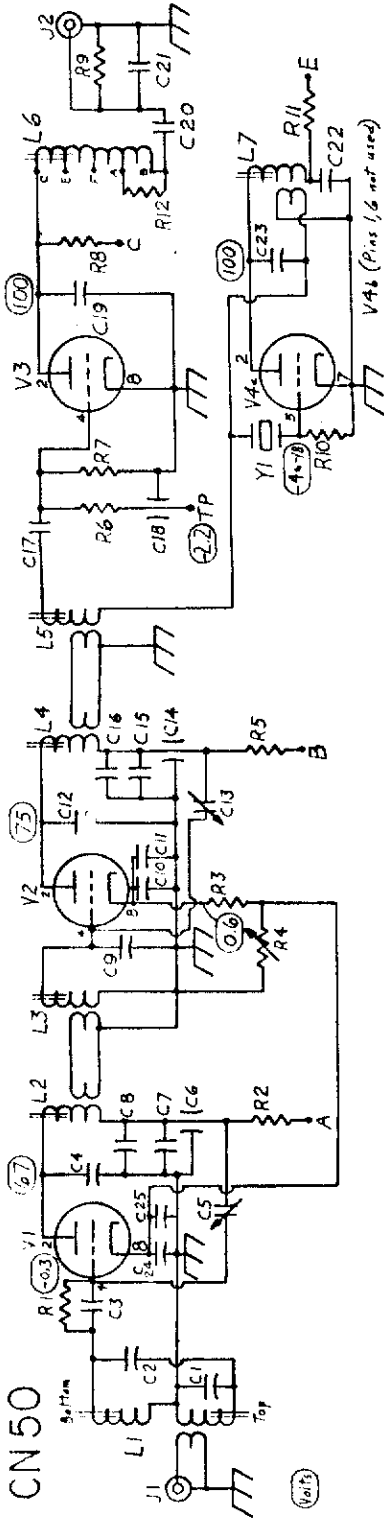

CN144

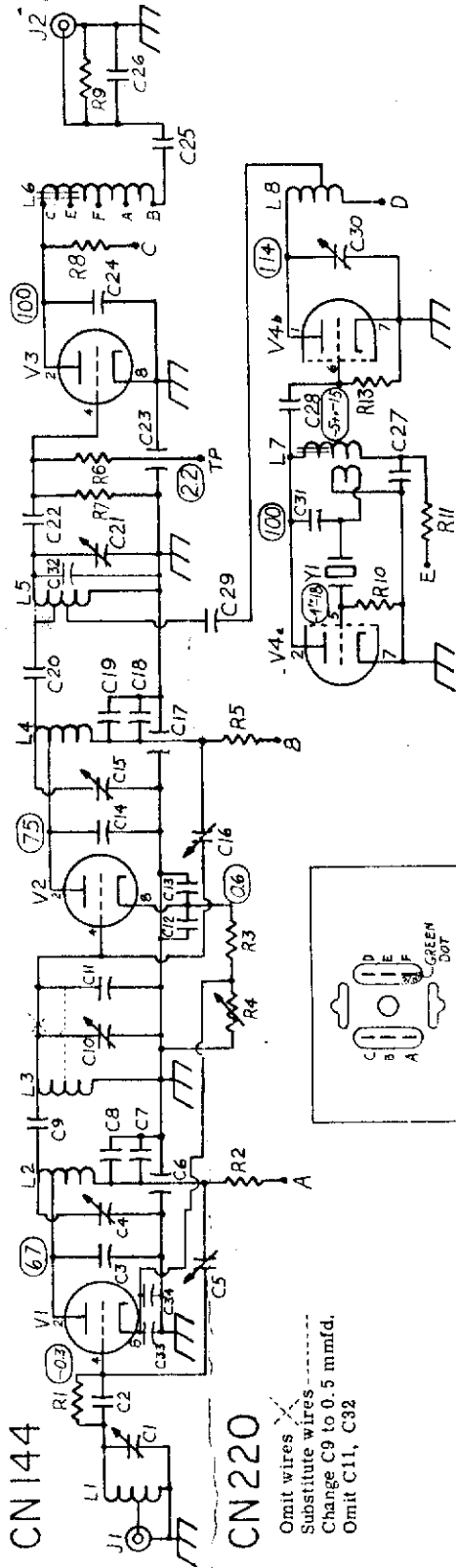

CN220

Omit wires ~~X~~
 Substitute wires ~~X~~
 Change C9 to 0.5 mmfd.
 Omit C11, C32

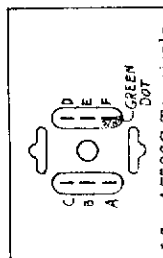

L6 - AT596C Terminals

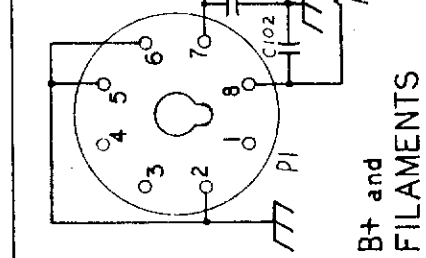

B+ and
 FILAMENTS

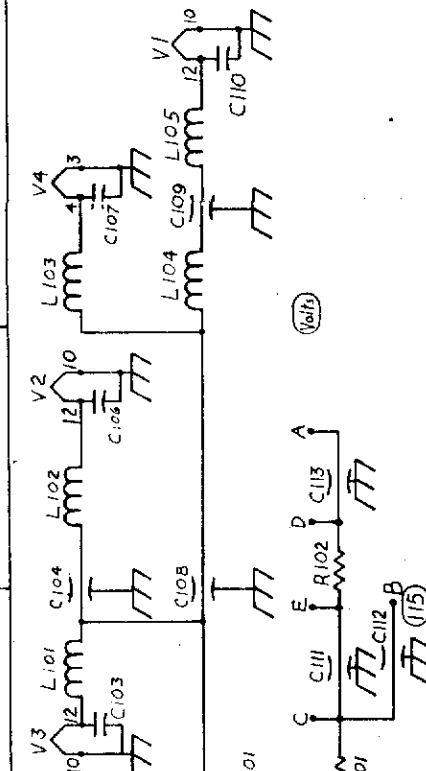

Filament circuit changes
 for 12 volt operation

6X4 Navigator Tube Bottom

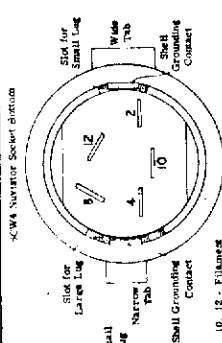

1 - Plate 4 - Grid 8 - Cathode 10 - 12 - Filaments

PARTS LIST

All capacitance values given in mmfd.
All resistance values given in ohms.

K = X 1,000 M = X 1,000,000
All resistors are 1/2 watt, except as noted.

CN-50		CN-144, 220		CN Filament and B+					
C 1	5 disc	L 1	Antenna transformer, Ameco CN50T1	C 1	1 to 8 trimmer	C33	1000 disc	C101	5000 disc
C 2	1 tubular	L 2	9 turn coil, Ameco CS-1	C 2	100 tubular	C34	1000 disc	C102	5000 disc
C 3	100 tubular	L 3	6 turn coil, Ameco CS-1 modified	C 3	5 disc	J 1	Antenna jack	C103	1000 disc
C 4	10 disc	L 4	9 turn coil, Ameco CS-1	C 4	1 to 8 trimmer	J 2	Output jack	C104	1000 feedthru
C 5	1 to 5 trimmer	L 5	9 turn coil, Ameco CS-1	C 5	1 to 5 trimmer	L 1	4 turns tap at 1-1/2	C106	1000 disc
C 6	1.5 feedthru	L 6	Output transformer, Ameco A7596C	C 6	1.5 feedthru	L 2	7 turns tap at 2	C107	1000 disc
C 7	10 disc	L 7	9 turn coil, Ameco CS-1	C 7	10 disc	L 3	2-1/2 turns	C108	1000 feedthru
C 8	10 disc	L 8	Output transformer, Ameco A7596C	C 8	10 disc	L 4	Same as L2	C109	1000 feedthru
C 9	5 disc	L 9	9 turn coil, Ameco CS-1	C 9	1.0 tubular	L 5	4 turns	C110	1000 disc
C10	1000 disc	L 10	9 turn coil, Ameco CS-1	C10	1 to 8 trimmer	L 6	Output transformer, Ameco A7596C	C111	1000 feedthru
C11	1000 disc	R 1	47K	C11	5 disc	L 7	Ameco CS-1	C112	1000 feedthru
C12	10 disc	R 2	6.8K, 1 watt	C12	1000 disc	L 8	See table	C113	1000 feedthru
C13	1 to 5 trimmer	R 3	100	C13	1000 disc	R 1	47K	L101	filament choke
C14	1.5 feedthru	R 4	1000 ohm rheostat	C14	5 disc	R 2	6.8K, 1 watt	L102	filament choke
C15	10 disc	R 5	6.8K, 1 watt	C15	1 to 8 trimmer	R 3	100	L103	filament choke
C16	10 disc	R 6	100K	C16	1 to 5 trimmer	R 4	1000 ohm rheostat	L104	filament choke
C17	22 disc	R 7	1.0M	C17	1.5 feedthru	R 5	6.8K, 1 watt	L105	filament choke
C18	1000 feedthru	R 8	4.7K	C18	10 disc	R 6	1.0 M	P 1	Power plug, octal male
C19	10 disc	R 9	330	C19	10 disc	R 7	100K	R101	100
C20	5000 disc	R 10	100K	C20	1.0 tubular	R 8	1.0 M	R102	100
C21	100 tubular	R 11	4.7K	C21	1 to 8 trimmer	R 9	330	V 1	6CW4 or 6DS4
C22	1000 disc	R 12	4.7K	C22	22 disc	R 10	100K	V 2	6CW4 or 6DS4
C23	See table	V 1	6CW4 or 6DS4	C23	1000 feedthru	R 11	4.7K	V 3	6CW4 or 6DS4
C24	1000 disc	V 2	6CW4 or 6DS4	C24	10 disc	R 12	100K	V 4	6J6
C25	1000 disc	V 3	6CW4 or 6DS4	C25	5000 disc	R 13	100K	Y 1	Crystal, see table
J 1	Antenna jack	V 4	6J6	C26	100 tubular	V 1	6CW4 or 6DS4		
J 2	Output jack	Y 1	Crystal, see table	C27	1000 disc	V 2	6CW4 or 6DS4		
				C28	22 disc	V 3	6CW4 or 6DS4		
				C29	1000 disc	V 4	6J6		
				C30	1 to 8 trimmer	Y 1	Crystal, see table		
				C31	See Table				
				C32	5 disc				

GUARANTEE

The American Electronics Co. guarantees each component to be free from defect and agrees to furnish a new part in exchange for the old, provided such part is returned to us intact, for our examination, with all transportation charges prepaid to our factory, within ninety (90) days from the date of purchase, and provided that such examination discloses, in our judgment, that it is thus defective and not a result of poor construction practices or use on the part of the kit constructor or user. In returning a part, the following conditions must be fulfilled: Identify the part number as listed in the parts list in this book. State the type and model of the equipment for which the component is required. List the dealer and date of purchase and provide complete details relative to the defect.

This warranty does not extend to any equipment which has been subjected to misuse, neglect, accident or improper wiring in violation of the instructions furnished by us.

This warranty shall not take effect and will be considered void unless the enclosed registration card is returned to us within ten (10) days of the date of purchase.

If trouble develops in your unit during the guarantee period which you cannot remedy yourself, write to our Service Department, listing all possible indications that might be helpful. We will then write to you and tell you what to do. If the unit is not in warranty or was built from a kit, you may return the unit to our factory where it will be placed in operating condition. The minimum charge for this service will be \$3.00 provided that it does not require more than one-half hour of bench work. Any unit that requires more than one-half hour of work will be held until the purchaser has received and approved an estimate of total repair costs. There will be a charge for parts replaced due to their being damaged in the course of construction.

NOTE: Before returning this unit, be sure that all parts are securely mounted. Equipment will be serviced only if it has been completely wired and assembled in accordance with the instructions contained in this manual. Equipment that has been constructed in any other manner, that has been modified in any way, that has been wired with acid core solder, soldering paste or liquid flux of any type, or that is incompletely assembled will not be repaired but will be shipped back to the sender COLLECT.

Attach a tag to the unit giving your name, home address and the trouble experienced. Pack very carefully in a rugged container. **THE CARTON THAT THE UNIT WAS PACKED IN IS NOT SUITABLE AS AN EXTERIOR SHIPPING CONTAINER.** Pack in a box at least two inches larger on all sides. Use sufficient packing material (cotton, shredded newspaper or excelsior) to make the unit completely immovable within the container. Ship by Prepaid Insured Parcel Post or Prepaid Railway Express to:

AMECO EQUIPMENT CORP.

178 Herricks Road
Mineola, L.I., N. Y.

Return shipment will be made by Express Collect or Parcel Post C. O. D.

We are not responsible for damage that occurs in transit. The consignee must file claims for recovery with the carrier. Note that a carrier cannot be held liable for damages in transit if packing, **IN HIS OPINION,** is insufficient.

We reserve the right to change parts and/or specifications at any time, without being obliged to modify existing units or those already sold in like manner.